

Biodegradation resistant sealant

Uses

Nitoseal PU12 is a two-part sealant designed to meet many of the requirements of the water industry in water retaining structures, sewage treatment and sea defence works. It is resistant to the bacteriological conditions associated with sewage treatment and silt accumulations in water storage. The abrasion resistance of Nitoseal PU12 makes it also appropriate for use for sealing movement joints in concrete sea walls subject to tidal scour.

The principal applications for Nitoseal PU12 are:

- Sludge digestion tanks
- Filtration and aeration tanks
- Culverts
- Raw water reservoirs
- Sea walls

Advantages

- Resistant to aerobic and anaerobic bacteriological attack
- Excellent adhesion under immersed conditions
- Abrasion resistant
- Separate component for accelerating the initial cure

Description

Nitoseal PU12 is a two-part, elastomeric joint sealant based on polyurethane technology. It is supplied in packs containing base compound and curing agent in the correct proportions which, when mixed, cure to form a tough rubber-like material. Adhesion to most commonly used construction materials is excellent.

The use of Nitoseal MS2 Primer is essential to ensure proper adhesion on porous surfaces.

In special circumstances, such as sealing sea defence works in tidal areas, a special Nitoseal PU12 accelerator component is available, to be added when mixing to enhance the initial cure rate, so that work can be completed between tides. At 10°C the seal can be subjected to tidal immersion approximately 60 minutes after application, without adverse effect.

Specification clauses

Joints shall be sealed, where designated, using Nitoseal PU12, two-part biodegradation resistant sealant manufactured and supplied by Fosroc. The sealant shall be mixed and applied strictly in accordance with the manufacturer's printed instructions.

Design criteria

Example of an expansion joint in a reservoir wall is shown below

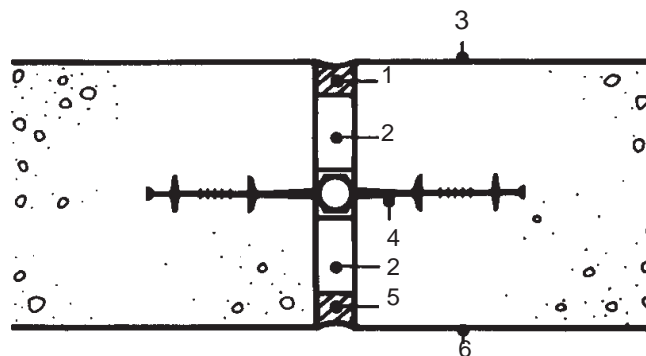

- | | |
|------------------|------------------------|
| 1 Nitoseal MS600 | 4 Supercast Hydrofoil* |
| 2 Hydrocell XL* | 5 Nitoseal PU12 |
| 3 Water face | 6 External face |

* Also available from Fosroc

Application instructions

Joint preparation

Joints to be sealed must be accurately formed. They must be dry, clean and frost free. Dust, dirt, weak laitance, old failed sealant and other foreign substances must be removed.

Ensure that expansion joint fillers are tightly packed and that no voids are left at the base of the sealing slot.

Insert a self-adhesive polyethylene bond breaking tape at the base of the joint. (Soft foam back-up material should not be used.)

Priming

Prime the sides of the sealing slot using the appropriate Fosroc primer. Apply by brush, working well in, ensuring complete coverage.

Porous substrates must be primed with Fosroc Primer MS2. Empty the entire contents of the hardener tin into the base tin and replace the base tin lid. Mix thoroughly by shaking for at least 2 minutes. Prime the joint face using a clean, dry brush. Avoid over application of primer causing puddles in the bottom of the joint.

Nitoseal PU12 should be applied between 30 minutes and 4 hours after priming. NB: Avoid using too much primer resulting in pools in the base of the joint.

If a joint is left unsealed for more than 4 hours, the primer should be removed by grit blasting or grinding and the joint re-primed.

Fosroc® Nitoseal PU12

Mixing

Add the curing agent to the base component tin. Mix thoroughly using a slow speed drill (300 to 500 rpm) fitted with a Fosroc Sealant Mixing Paddle. Mix for 3 minutes then scrape down the sides and bottom of the tin using a spatula, mix for a further 2 minutes. Only thorough mixing, including material right at the bottom of the tin, will result in proper curing. In cold weather Nitoseal PU12 mixes more easily if stored overnight at room temperature.

Note: If Nitoseal PU12 accelerator is used it should be stirred well before adding to the base with the curing agent prior to mixing.

Mix using a slow speed drill (300 to 500 rpm) fitted with a Fosroc Sealant Mixing Paddle for not less than 4 minutes until a uniform colour is achieved with no streakiness.

Application

Load the mixed Nitoseal PU12 into a Fosroc 'G' gun using a Follower Plate. Compact the Nitoseal PU12 into the primed joint. Tool off leaving a smooth finish.

Finishing

Nitoseal PU12 can be finished by tooling-off smooth using a metal or wooden spatula. A minimum amount of detergent may be used to ease this operation. Remove all masking tapes immediately after tooling. Excessive tooling can cause surface drag, this should be avoided.

Cleaning

Clean equipment immediately after use with Fosroc Equipment Cleaner.

Estimating

Packaging

Nitoseal PU12 is supplied in a carton of 4 x 2.0 litre units.

Nitoseal PU12 accelerator is supplied in small, lever lid tins in packs of PU12. One tin of accelerator is required for each 2 litre tin of Nitoseal PU12.

Fosroc Equipment Cleaner is supplied in 5 litre tins.

Properties

Technical data — Nitoseal PU12

Form:	Two-part compound Base: White paste Curing agent: Dark-grey paste
Storage life:	12 months in original containers in cool, dry conditions
Solids content:	100%
Density:	1.44 kg/litre
Colour:	Grey
Physical/chemical change:	Chemical cure
Application temperature:	5°C to 50°C
Pot life:	2 to 3 hours at 25°C With accelerator 20 minutes at 25°C
Cure rate:	48 hours at 25°C With accelerator 24 hours at 25°C
Cure time:	48 hours at 25°C 96 hours at 10°C Permanent immersion in water should not occur until full cure has taken place

Note: The above times will be reduced by approximately 50% if the accelerator is used.

In a tidal situation, the sealant should incorporate the accelerator and the sealing operation should be completed at least 1 hour at 10°C prior to immersion.

Hardness Shore 'A' at 25°C:	35 to 40
Flammability:	Burns but does not readily support combustion
Biological resistance:	Good resistance to both aerobic and anaerobic conditions normally occurring in sewage treatment works
Movement accommodation factor:	20% in butt joints

Technical data — Nitoseal PU12 accelerator

Flash point:	Over 65°C
Pack size:	50 ml



Fosroc® Nitoseal PU12

Guide to Nitoseal PU12 quantities

Joint size in mm (w x d)	Litres per metre run	Metre run per 2 litre
5 x 5	0.025	80.0
10 x 5	0.050	40.0
20 x 10	0.200	10.0
25 x 15	0.375	5.3
30 x 15	0.450	4.4
40 x 20	0.800	2.5
50 x 25	1.300	1.6

Guide to Nitoseal MS2 Primer coverage

Linear metres per pack of primer	
Joint depth mm	Nitoseal MS2 Primer 0.75 litre pack
10	500 - 600
15	333 - 400
20	250 - 300
25	200 - 240
30	166 - 200
40	125 - 150
50	100 - 120

Yields are theoretical and no allowance has been made for variations in joint dimensions, substrate or wastage.

Storage

Storage life of 12 months. Store in original containers in cool, dry conditions between 5°C and 27°C.

Fosroc Primer MS2 and Fosroc Equipment Cleaner must be stored in accordance with the Highly Flammable Liquids and Liquefied Petroleum Gases Regulations 1972.

Precautions

Health and safety

Nitoseal PU12, Nitoseal PU12 accelerator, Primer MS2, Fosroc Equipment Cleaner:

For further information refer to appropriate Product Safety Data Sheet.

Fire

Nitoseal PU12 and Nitoseal PU12 accelerator are non-flammable.

Nitoseal MS2 Primer and Fosroc Equipment Cleaner are highly flammable. See below details of flashpoint:

Flashpoint

Nitoseal MS2 Primer	30°C
Fosroc Equipment Cleaner :	44°C

Fosroc and Nitoseal are trademarks of Fosroc International Limited

+44 (0) 1827 262444

enquiryuk@fosroc.com



Important note

Fosroc products are guaranteed against defective materials and manufacture and are sold subject to its standard Conditions for the Supply of Goods and Services, copies of which may be obtained on request. Whilst Fosroc endeavours to ensure that any advice, recommendation, specification or information it may give is accurate and correct, it cannot, because it has no direct or continuous control over where or how its products are applied, accept any liability either directly or indirectly arising from the use of its products, whether or not in accordance with any advice, specification, recommendation or information given. All Fosroc datasheets are updated on a regular basis. It is the user's responsibility to obtain the latest version.

Fosroc International Limited

Drayton Manor Business Park
Coleshill Road, Tamworth,
Staffordshire B78 3XN, UK

telephone:
+44 (0)1827 262222

email:
enquiryuk@fosroc.com

www.fosroc.com

